

OPERATOR'S MANUAL

91SR S (Helicopter Engine/ Part No.YS0074)

Fig.1

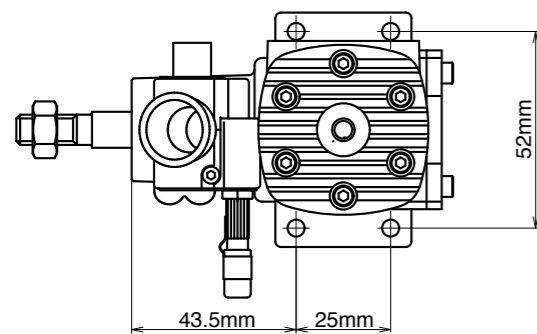

SPECIFICATIONS

| | |
|---------------|---------------|
| Bore | 27mm |
| Stroke | 26mm |
| Displacement | 14.89cc |
| Weight | 553g |
| Practical rpm | 2,000 ~17,000 |

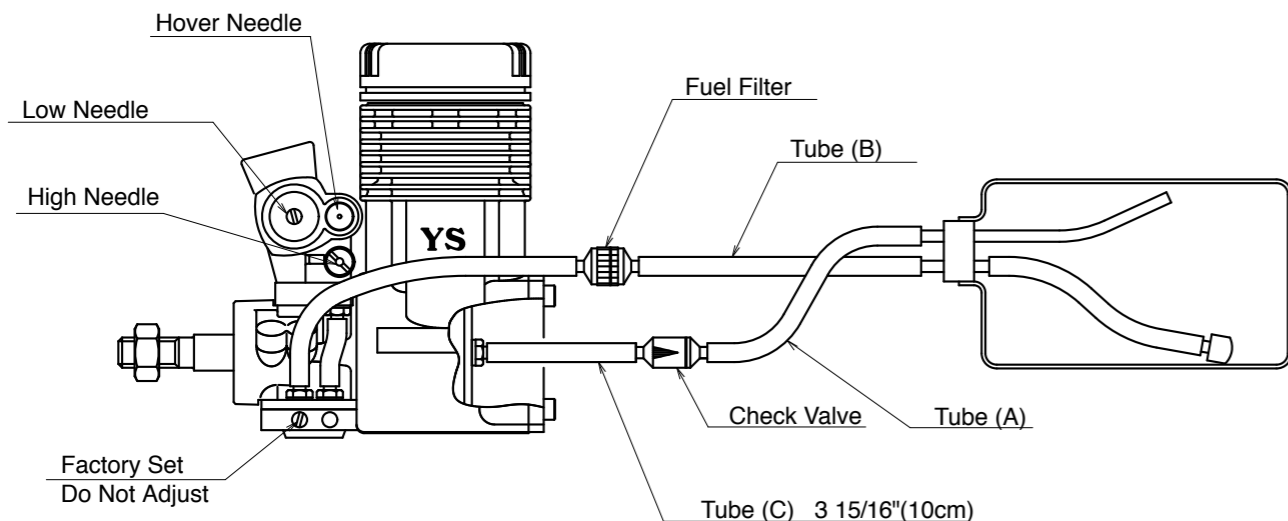

FEATURES

The 91SR S is the latest in helicopter engine technology from YS.

- New stroke design for superior operation
- New carburetor design for easier adjustments.
- Factory preset fuel regulator.

CAUTION

Using gear ratios higher than 9.0 to 1 may result in engine damage from overspeed.

GEAR RATIO

You should be using an engine to main rotor gear ratio of 1-7.5 to 1-8.0. Please check with your helicopter manufacturer to obtain the correct gear ratio.

INSTALLATION

1. The fuel lines should be connected to the fuel tank as shown in the above figure. Be careful to install the check valve in the correct direction. Since the tank is exposed to high pressures, be sure that all connections are tight to prevent pressures leakage.
2. Since the engine is sensitive to dirt in the fuel, a fuel filter must be used. (We recommend the YS1195 fuel filter.)

3. Tube(C) should be set exactly at 3 15/16" or (10cm) between the engine and check valve. DO NOT use any other type of check valve. The check valve is designed exclusively for the 91SR S.
4. Adjust your throttle linkage and curve using the alignment indentations on the carburetor body located on the throttle arm side of the carb body. PLEASE NOTE that the hover position is at 40% see FIG 2.

START UP

1. Always remove Tube(A) at the check valve first before fueling. The fuel tank is pressurized and you need to relieve the pressure first. Disconnect Tube(B) at the filter and fill the tank. Reconnect Tube(A) and (B).
2. From the fully closed (clockwise) position, turn the needle valves counter clockwise as follows.

STARTING SETTING / OPERATING SETTING

| | | |
|---------|-----------|------------|
| • Hover | 1.75 open | 1.75 ~1.50 |
| • Low | 1.25 open | 0.75 ~0.50 |
| • Full | 1.25 open | 1.25 ~0.75 |

3. Close the throttle to the idle position and connect the glow plug driver. The engine is now ready for starting.

BREAK-IN

It is not necessary to mount this engine on a set stand for break-in. However, the engine should be adjusted slightly on the rich setting for the first few flights to insure proper break-in. Always use a good quality fuel which contain 15 ~30% nitromethane and an oil content of 18 ~23% low viscosity oil.

NEEDLE VALVE ADJUSTMENT

Idle, Hover and High needle valves all work the same way. Turning the needles clockwise will lean the fuel mixtures and counter clockwise will richer the fuel mixtures.

1. Set needles as described in START-UP.
2. Start the engine and check idle. Adjust as needed.
3. Lift helicopter into a hover and check for the correct rotor RPM recommended by the kit manufacture. Once this is done take note of the amount of smoke being produced by the muffler. The mixture is correct for hover when there is a steady stream of smoke being produced.
4. Land the helicopter for approximately 20~30 seconds. Lift the helicopter into a hover again taking note of the transition from idle to hover. If the engine exhibits a large amount of smoke and the throttle response is sluggish, you will need to adjust the idle and or the hover needle leaner to achieved a smooth transition. If the engine detonates and the smoke is inconsistent or a small amount is produced, the mixture is too lean.

5. The high speed needle refines the fuel mixture for forward flights without affecting the hovering adjustment. After the engine is started and warmed up, lift off into a hover and check that the engine is running smooth with a good trail of smoke. If everything is fine, open the throttle and enter forward flight. Take note of the amount of smoke like we did in a hover adjustment. It is correct when you see a noticeable steady smoke trail. Adjust the high-speed needle valve to obtain slightly rich but consistent setting.

STOPPING THE ENGINE

1. Fully close the throttle barrel to stop the engine.
2. As soon as the engine stops running, be sure that a fuel line clamp is used in Tube(B) to prevent fuel from flowing into the engine.
3. On the final flight of the day, the fuel line clamp should be used to stop the engine in order to prevent rust and corrosion.

FUEL AND GLOW PLUG

We have found that the fuel and glow plugs listed below will give the best engine performance.

Fuel
Powermaster 30% Special Heli Blend
Cool Power 30% Special Heli Blend

Glow Plug _ YS #2 Enya #3 OS #8

IMPORTANT!

Silicone rubber is used in many parts of the YS engine. Use only glow fuel of methanol for cleaning. Gasoline and other volatile solutions will damage silicone if used.

WARRANTY

Strict quality control is implemented by our factory in all phases, from parts manufacturing to final assembly. If performance deteriorates or a part fails due to a manufacturing error, YS Parts and Service will repair or replace the engine at no charge in the period of one year from date of purchase. Warranty does not cover normal maintenance. Should the engine be modified, incorrectly assembled or abused, there will be a normal charge for parts and labor.

Fig.2

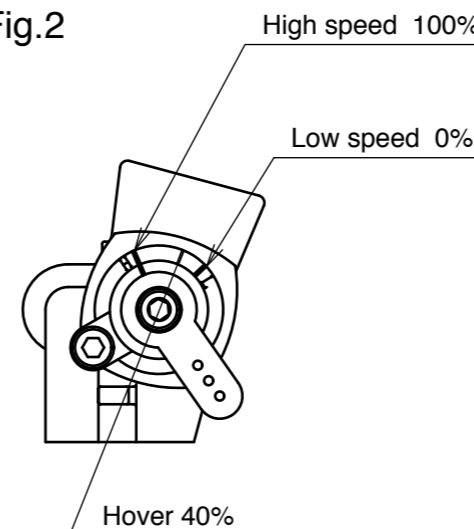

| NO. | PART# | DESCRIPTION | QTY |
|-----|--------|---------------------------|-----|
| 1 | YS6505 | Crankcase | 1 |
| 2 | YS6510 | Cylinder Head | 1 |
| 3 | YS5830 | Head Gasket | 1 |
| 4 | YS4785 | Head Screws | 6 |
| 5 | YS6520 | Cylinder Liner | 1 |
| 6 | YS6525 | Piston | 1 |
| 7 | YS5850 | Piston Ring | 1 |
| 8 | YS2385 | Wrist Pin | 1 |
| 9 | YS4803 | Wrist Pin Retainer | 2 |
| 10 | YS4805 | Con Rod | 1 |
| 11 | YS6530 | Crankshaft | 1 |
| 12 | YS1050 | Front Bearing | 1 |
| 13 | YS5860 | Rear Bearing | 1 |
| 14 | YS5243 | Drive Washer Spacer | 1 |
| 15 | YS0490 | Propeller Nut | 1 |
| 16 | YS5865 | Back Plate | 1 |
| 17 | YS5870 | Back Plate O ring | 1 |
| 18 | YS1070 | Back Plate Screw | 4 |
| 19 | YS5880 | Carburetor Body | 1 |
| 20 | YS4830 | Carburetor Gasket | 1 |
| 21 | YS5885 | Throttle Barrel | 1 |
| 22 | YS1090 | Throttle Barrel Retainer | 1 |
| 23 | YS4485 | Hover Needle Valve | 1 |
| 24 | YS2695 | Hover Needle O Ring | 1 |
| 25 | YS2700 | Hover Needle Seat | 1 |
| 26 | YS2705 | Hover Needle Seat O Ring | 2 |
| 27 | YS2710 | Needle Detent | 1 |
| 28 | YS4140 | High Speed Needle | 1 |
| 29 | YS2695 | High Speed Needle O Ring | 1 |
| 30 | YS4845 | Low Speed Needle | 1 |
| 31 | YS4150 | Low Speed Needle O Ring | 1 |
| 32 | YS0200 | Throttle Arm | 1 |
| 33 | YS2435 | Carburetor Screws | 2 |
| 34 | YS4850 | Carburetor Subplate | 1 |
| 35 | YS2445 | Regulator Subplate | 1 |
| 36 | YS4155 | Regulator Assy. | 1 |
| 37 | YS2460 | Diaphragm | 1 |
| 38 | YS2480 | Regulator gasket | 1 |
| 39 | YS2475 | Regulator Screws | 2 |
| 40 | YS3036 | Nipple | 1 |
| 41 | YS2510 | Check Valve | 1 |
| | YS5890 | Gasket Set | |
| | YS5875 | Carburetor Assy. | |
| | YS5895 | O ring set | |
| | YS6515 | Piston / Ring / Liner Set | |
| | YS4480 | Needle Valve Assy. | |

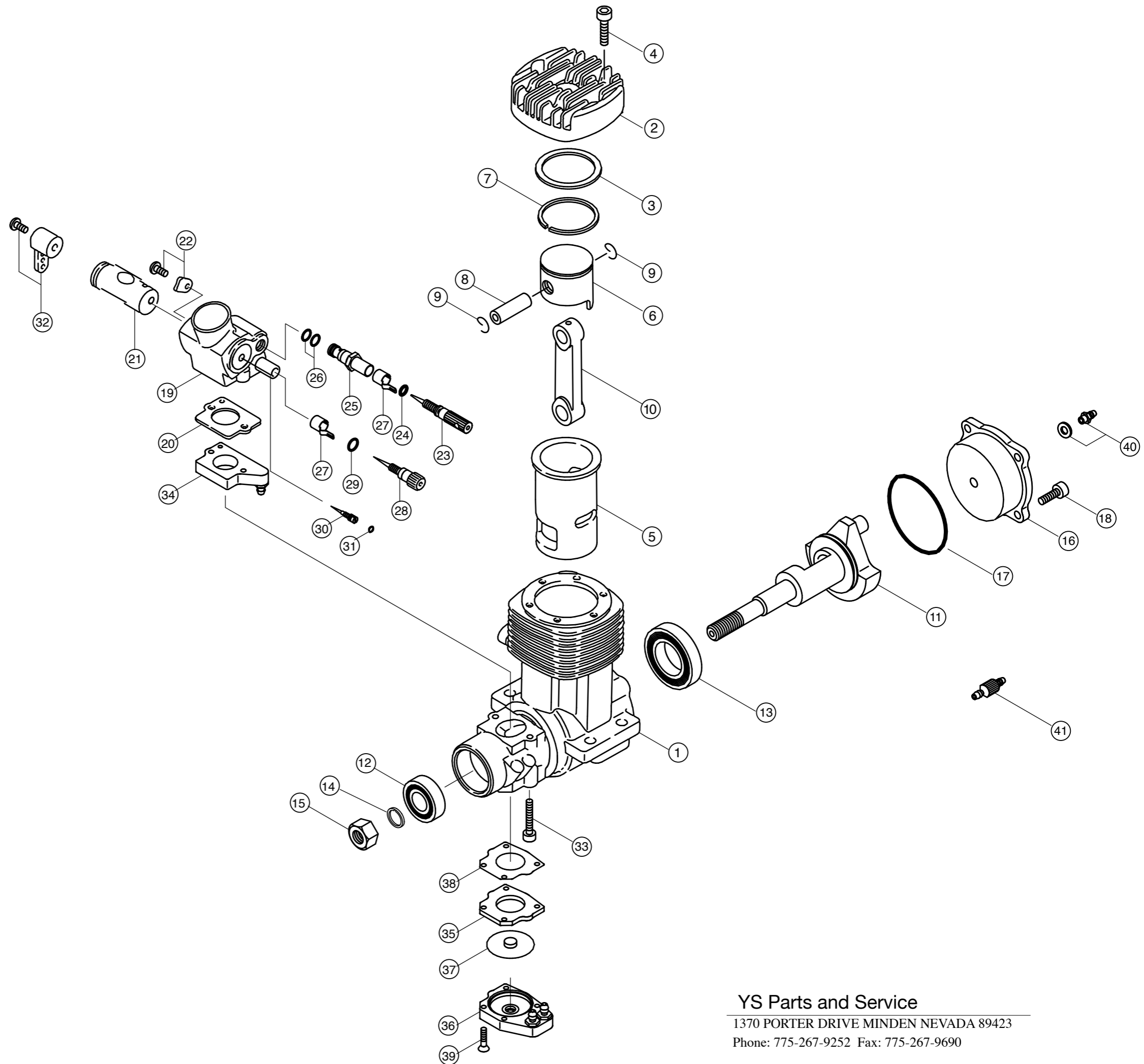

YS Parts and Service
 1370 PORTER DRIVE MINDEN NEVADA 89423
 Phone: 775-267-9252 Fax: 775-267-9690