

OPERATOR'S MANUAL

FZ110 (Supercharged.Part No. YS0083)

FIG.1

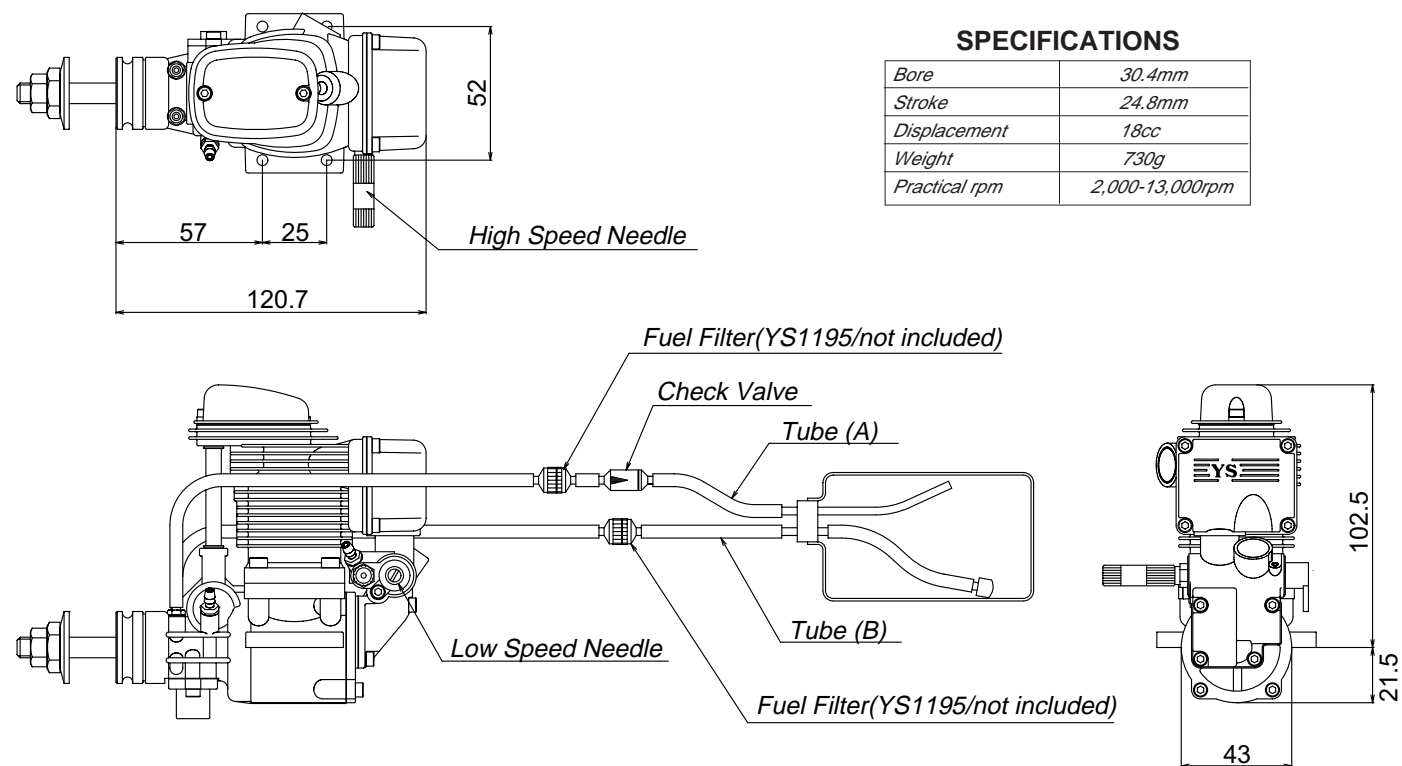

SPECIFICATIONS	
Bore	30.4mm
Stroke	24.8mm
Displacement	18cc
Weight	730g
Practical rpm	2,000-13,000rpm

FEATURES

The FZ110 is the most powerful 91 four cycle engine available. This engine offers many exclusive features that have been proven on other YS engines.

- Supercharged system with simplified structure to keep weight to a minimum while still retaining maximum efficiency.
- Air chamber that uses crankcase pressure coupled with a double throttle valve system which allows a bigger charge of fuel and air mixture to enter the intake valve for more power.
- Same proven piston design as the 140L limited which creates more crankcase pressure for a more consistent fuel flow to the regulator.
- Fuel injection system for superior throttle response. This system is unaffected by tank position or by the attitude of the model.

GLOW PLUG

Select the most appropriate glow plug from those designed specifically for 4 cycle engines. GLOW plug selection greatly affects the maximum engine output and low idle. If RPM's decrease or stop when the booster cord is removed, replace the plug. We recommend YS#4 or OS Type F.

INSTALLATION

1. Connect the engine to the tank as shown in fig.1. Since high pressure is applied to the tank, tighten all connections carefully. Care must be taken to prevent pressure leakage due to undertightening of the check valve or by kinking the fuel lines.
2. Always use a fuel filter. We recommend the YS fuel filter.
3. Match the direction of the check valve arrow to fig.1, with the arrow facing towards the tank.

PROPELLER INSTALLATION

Due to the high torque of the FZ91 engine, we have equipped it with double locknuts for safety.

1. Mount the propeller and tighten the rear nut. Next, tighten the front nut as shown in fig.2.
2. Select a good quality propeller that will turn in the 8,000 to 11,000rpm range. We recommend sizes 13.5-10-13, 14-10-12.

FIG.2

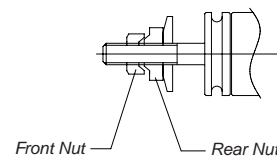

START-UP

1. Remove tube (B) from the filter; remove tube (A) from the check valve, then fill the tank. Caution: If tank is filled or under pressure remove tube (A) first; then tube (B). Fuel will eject if tube (B) is removed first while the tank is pressurized.
2. Open the needle valve 1 1/2 from the fully closed position.
3. Open the throttle fully and slowly turn the propeller ten turn. This primes the system by pressurizing the tank and sending fuel to the carburetor.
4. Pour several drops of fuel into the carburetor.
5. Close the throttle to the idle position and connect the glow plug cord. The engine is now ready for starting.

Do not attempt to start at full throttle, as this is very dangerous.

BREAK-IN

To maximize engine performance and increase durability, please follow this break-in procedure:

1. Use the same size (or slightly smaller) propeller than you intend to use in flying.
2. Use a good quality fuel which contains 15-20% nitromethane and an oil content of 15-20%. Synthetic or castor oil can be used, or a combination of synthetic and castor. Do not use four cycle fuel due to low oil content.
3. The needle valve should be set so that the engine is running at a rich setting. Run the engine approximately 20 minutes with this setting.
4. Mount the engine to the model and fly ten times with this setting. This concludes the break-in procedure. It is advisable to always use a slightly rich setting to keep the moving parts lubricated, even after the break-in period.

HIGH SPEED ADJUSTMENT

1. Adjustment of high speed is done by the carburetor needle valve. When the needle valve is turned clockwise, the mixture is leaner. When it is turned counterclockwise, the mixture is richer. A good starting position for the high speed needle valve is 1 1/2 turns open from fully close position.
2. When the engine is started, open the throttle gradually. Next, find the peak position (highest RPM) by adjusting the needle valve. Then the needle valve should be opened approximately 1/8 of a turn from full RPM to achieve best performance. The engine may stop if the throttle is opened to full immediately after starting. Wait until the engine temperature rises and then open the throttle slowly.
3. For flying, it is advisable to use a slightly richer mixture setting. By using a richer mixture, the engine temperature is maintained and RPM stability improves.

LOW SPEED ADJUSTMENT

This engine is equipped with a new low speed needle valve to adjust the mixture from low to mid throttle. This needle valve is located on the side of the throttle barrel opposite the throttle arm (fig.1).

1. Open the low speed needle to 1 1/2 turns from fully closed position.
2. The low speed needle valve should be set after the high speed needle valve has been adjusted. Close the throttle gradually to a idle (approximately 2500rpm). Let it idle for 20 to 30 seconds and then slowly advance the throttle. The adjustment is satisfactory at low speed if transition is smooth at this time.
3. If the engine is running rough on idle, the low speed mixture is rich. If the engine starts to speed up and dies on idle or starts to detonate, when advancing the throttle, the mixture is lean. Turn the low speed needle valve clockwise to richen and counterclockwise for a leaner mixture (note that the direction of the low speed needle valve is opposite the high speed needle valve). Adjustments to the low speed needle valve should be 1/8 to 1/4 of a turn increment at a time to achieve smooth throttle response.

FIG.3

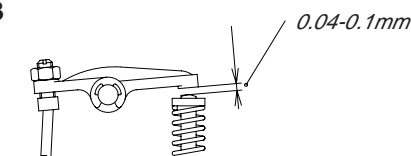

TAPPET CLEARANCE ADJUSTMENT

1. Tappet clearance is factory preset. No adjustment is necessary unit after 1 hour of operation (including break-in period).
2. Clearance adjustment should be done when the engine is cool. When the engine temperature is high, clearance is higher due to thermal expansion.
3. The proper clearance setting should be at 0.04-0.1mm. The adjustment is achieved by loosening the locknut (fig.3) and turning the adjusting screw. Tighten the locknut after the adjustment is achieved. After the initial 1 hour adjustment, this procedure should be performed after every 2 hours of use.

CAM GEAR TIMING ADJUSTMENT

If for some reason you have to disassemble your engine, please follow these important steps on reassembling the cam gear box.

1. Turn drive washer so the piston is at top dead center. This can be accomplished by aligning the "I" mark on the drive washer to the top of the mold line on the engine front case.
2. When reinstalling the cam gear, the side with a point mark should be facing the opening of the cam gear box. Note that it should also be mounted with the point mark located towards the top of the engine just below the cam followers.

DIAPHRAGM AND CHECK VALVE DISASSEMBLY

Diaphragm:

1. Remove the adjustment screw of the valve, and then remove the inside valve and spring.
2. Clean the inside with alcohol or appropriate cleaner. Reassemble.
3. Screw in the regulator screw until flush with the diaphragm body.

Check valve:

1. Open the valve by rotating the body counterclockwise.
2. Reassemble the check valve carefully.

IMPORTANT!

1. The regulator adjusting screw on this engine is factory set. No further adjustments are necessary. If for some reason you have to disassemble the regulator assembly, the regulator adjusting screw should be set flush with the regulator body.
2. Silicone rubber is used in many parts of the YS engine. Use only glow fuel or methanol for cleaning. Gasoline and other volatile solutions will damage the silicone if used.

WARRANTY

Strict quality control is implemented by our factory in all phases, from parts manufacturing to final assembly. If performance deteriorates or a part fails within one year of purchase due to a manufacturing error, YS performance will repair or replace the engine at no charge. **Warranty will not cover normal wear.**

Should the engine be modified or incorrectly assembled, there will be a normal charge for parts and labor. The use of four cycle fuel due to low oil content will also void warranty.

FZ110 PARTS LIST

#	PART	DESCRIPTION	QTY
1	YS4870	Crankcase	1
2	YS4880	Cylinder Head	1
3	YS1590	Intake Valve	1
4	YS1600	Exhaust Valve	1
5	YS0540	Valve Spring Set	2
6	YS2030	Spring Retainer Set	2
7	YS2040	Valve Spring Retainer Clips	4
8	YS1611	Cylinder Head Gasket	1
11	YS1630	Head Screws	4
12	YS1640	Valve Cover	1
13	YS1650	Valve Cover Gasket	1
14	YS1660	Valve Cover Screws	2
15	YS1670	Rear Air Chamber	1
16	YS1680	Air Chamber Gasket	1
17	YS1690	Air Chamber Screws	4
18	YS1700	Air Chamber O-Ring	1
19	YS4320	Crankshaft	1
20	YS1720	Rear Bearing	1
21	YS1050	Front Bearing	1
22	YS1730	Front Bearing Oil Seal	1
23	YS4325	Drive Washer	1
24	YS4330	Drive Washer Retainer	1
25	YS0425	Propeller Washer	1
26	YS0830	Propeller Nut Set	2
27	YS2195	Piston	1
28	YS0615	Piston Ring	1
29	YS0605	Wrist Pin	1
30	YS0610	Wrist Pin Retainer	2
31	YS1790	Rocker Arm Set	2
32	YS0560	Tappet Adjusting Screw Set	2
33	YS0565	Tappet Lock Nut	2
34	YS1800	Rocker Arm Shaft	1
35	YS1810	Rocker Arm Screw	1
36	YS0580	E-Ring Set	2
37	YS0670	Cam Gear	1
38	YS1820	Cam Gear Cover	1
39	YS1830	Cam Gear Cover O-Ring	1
40	YS1840	Cam Gear Cover Screws	2
41	YS0705	Cam Gear Bearing	2
42	YS0675	Cam Follower	2
43	YS1850	Push Rods	2
44	YS1860	Push Rod Covers	2
45	YS0690	Push Rod Cover O-Ring	4
46	YS1870	Con Rod	1
47	YS1880	Back Plate	1
48	YS1890	Disc Valve	1
49	YS1900	Disc Valve Pin	1
50	YS1910	Disc Valve Pln Retainer	2
51	YS1920	Disc Valve Pln E-Ring	1
52	YS1930	Back Plate Gasket	1
53	YS1940	Back Plate Screws	4
54	YS4305	Carburetor Body	1
55	YS4310	Throttle Barrel	1
56	YS2050	Low Speed Needle Valve	1
57	YS2060	Low Speed Needle Valve O-Ring	1
58	YS4315	Throttle Barrel Seal	1
59	YS1090	Throttle Barrel Retainer	1
60	YS0200	Throttle Arm	1
61	YS0785	Throttle Stop Screw	1
62	YS0790	Throttle Stop Spring	1
63	YS2690	Needle Valve	1
64	YS2695	Needle Valve O-Ring	1
65	YS2700	Needle Seat	1
66	YS2705	Needle Seat O-Ring	2
67	YS2710	Needle Valve Detent	1
68	YS1970	Carburetor Gasket	1
69	YS2080	Carburetor Screws	2
70	YS0715	Regulator Body	1
71	YS0195	Regulator Adjusting Screw	1
72	YS0725	Regulator Adjusting Screw O-Ring	1
73	YS0730	Diaphragm	1

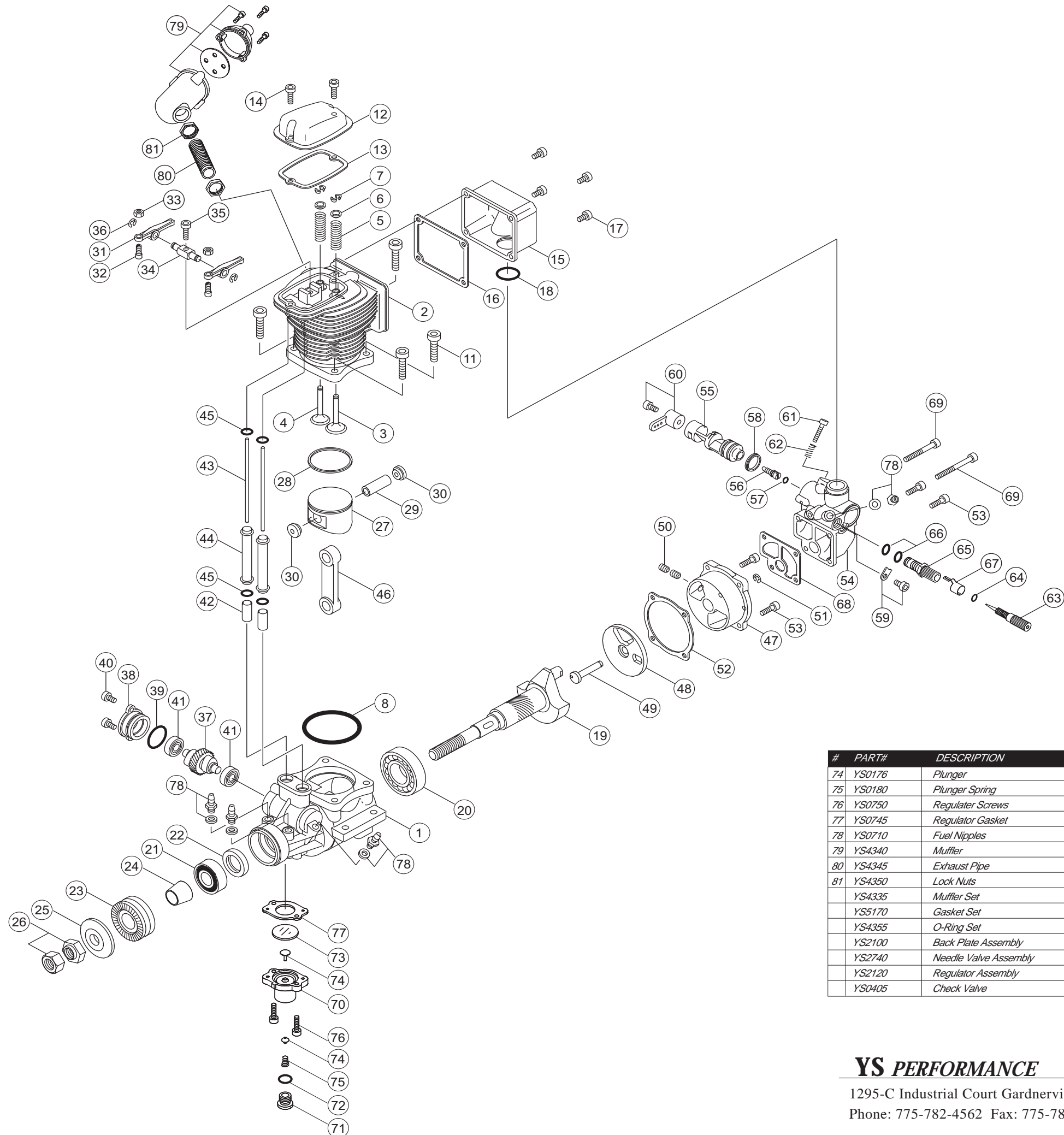

#	PART#	DESCRIPTION	QTY
74	YS0176	Plunger	1
75	YS0180	Plunger Spring	1
76	YS0750	Regulator Screws	2
77	YS0745	Regulator Gasket	1
78	YS0710	Fuel Nipples	4
79	YS4340	Muffler	1
80	YS4345	Exhaust Pipe	1
81	YS4350	Lock Nuts	2
	YS4335	Muffler Set	1
	YS5170	Gasket Set	1
	YS4355	O-Ring Set	11
	YS2100	Back Plate Assembly	1
	YS2740	Needle Valve Assembly	4
	YS2120	Regulator Assembly	1
	YS0405	Check Valve	1

YS PERFORMANCE

1295-C Industrial Court Gardnerville, NV89410
 Phone: 775-782-4562 Fax: 775-783-8518